

Energy Storage LiFePO4 Battery User manual



Important safety instructions

Important safety instructions

Please keep this manual for future reference.

This manual contains all the safety installation and operation instructions of the M series energy storage LiFePO₄battery.

Please read all instructions and precautions in the manual carefully before installation and use.

1. To avoid personal injury, users should not disassemble it by themselves, since the energy storage LiFePO₄battery has unsafe voltage inside. If need repairs, please contact our company's professional maintenance personnel.
2. Do not install the energy storage LiFePO₄battery in a place where children can touch.
3. Do not install the energy storage LiFePO₄battery in harsh environments such as damp greasy, flammable, explosive, or dust accumulation.
4. When the energy storage LiFePO₄battery is working, please do not open the box.
5. It is recommended to install a suitable fuse or circuit breaker externally.
6. After installation, check whether all line connections are tight to avoid the risk of heat accumulation due to virtual connection.
7. Energy storage LiFePO₄ battery shall be charged with DC power supply, parallel connection with other AC power supply or different voltage and brand batteries is prohibited.

Contents

1. Basic information	3~4
2. Installation process	5
3. Installation instructions	6~8
3.1 Installation notes	6
3.2 Installation and wiring	6
3.3 Schematic diagram of the installation	7~8
3.4 Recommended external wiring diameter and switch selection	8
4. Schematic diagram of connecting	9~10
5. LED instructions	11~12
6. BMS communication settings	13~14
7. LCD screen description	15~16
8. Technical parameter list	16
9. Maintenance and conservation	17
10. Warranty record card	18

1. Basic information

1.1 Product overview

M series energy storage battery is mainly used in the field of household power storage. At the same time, it is also suitable for the internal energy storage of RV, household energy storage and temporary buildings. It adopts high-performance and long-life lithium iron phosphate battery as the basic energy storage unit, combined with advanced lithium-ion battery management system industrial design of household products and other technologies. Ensure that products have high reliability and high industrialization standards. M series energy storage battery covers the energy demand of a single machine from the 5.0kwh to 14.3kwh, and the rated output voltage is 51.2V. M series products have external parallel function, which greatly improves the convenience of use.

Through scientific and reasonable active heat dissipation, M series energy storage battery improves the consistency of internal temperature field, prolongs service life, and enables the product to continuously output high current.

1.2 Features

- ◆ The external LCD screen is used to monitor the energy storage battery data and operating status in real time.
- ◆ The battery adopts high-performance lithium iron phosphate battery with high safety performance and long service life.
- ◆ M series energy storage battery adopts intelligent air cooling and heat dissipation to improve the reliability of the product.
- ◆ External weak current switch reduces product power consumption and improves the safety of transportation and storage.
- ◆ With RS232/RS485/CAN communication function, it can easily communicate with the equipment with communication.
- ◆ External wireless module can be connected for remote data monitoring and corresponding control.
- ◆ The energy storage battery is equipped with wheel, which can meet the installation and use in different places.
- ◆ It has multiple protection functions to protect the safety of power supply in an all-round way.
- ◆ The output is stable and can be connected to different loads with in the voltage rang.
- ◆ Support up to 15 independent modules for parallel use.

1.3 Function description

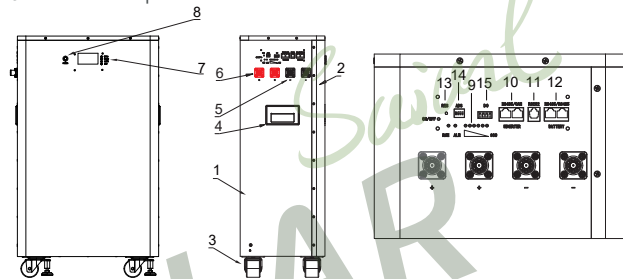

1	Side plate	2	Front plate
3	Wheel	4	Handle
5	M6 Negative Terminal(2PCS)	6	M6 Positive Terminal(2PCS)
7	Color touch screen	8	ON/OFF

- ◆ 9 SOC Display: 6 LED indicator with each one indicates about 17% SOC (State of Charge).
- ◆ 10 "RS485/CAN" battery can communicate with the INVERTER through RS485/CAN interface so that the inverter can monitor all kinds of battery information, including battery voltage current, temperature, status, SOC, SOH etc.. The default baud rate is 9600bps.
- ◆ 11 RS232: it can monitor the single pack information by computer.
- ◆ 12 RS485/RS485: this interface is used in parallel with battery strings, the master-controlled Pack communicates with the slave-controlled Pack through the RS485 port, so that the information of all packs can be viewed through the RS485/CAN port by the master-controlled Pack. BTW, this RS485 port cannot be used for parameter setting and corresponding controlled operation.
- ◆ 13 Reset: When the PACK is in the sleep state, press this key (3-6s) and release it to activate. If the PACK is in the active state, press this key (3-6s) and release it to sleep.
- ◆ 14 When "ADS" is used for parallel use of battery packs, different packs can be distinguished by hardware address, and the hardware address of each PACK in the whole battery stack is unique, and the hardware address can be set in sequence by DIP switch, the definition of switch refer to "Instructions for Selecting Communication Address";
- ◆ 15 Dry contact AM1 normally OPEN and CLOSED during fault protection; Dry contact AM2 normally OPEN and CLOSED during low energy alarm.

2. Installation process

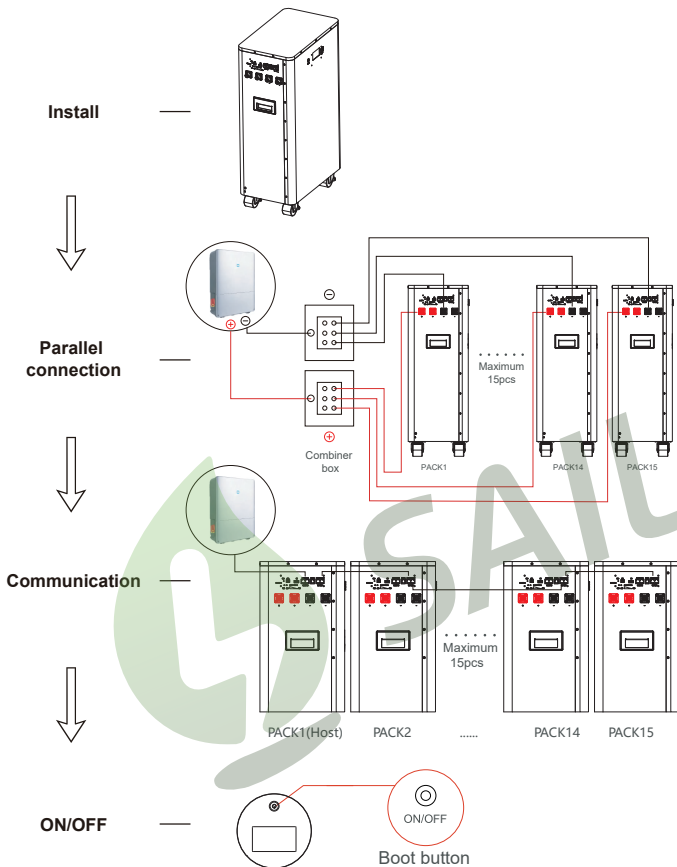

3. Installation instructions

3.1 Installation notes

Before installation, please read this manual carefully and familiarize the installation steps.

- (1) Be sure to leave a certain space around for heat dissipation during installation.
- (2) Avoid sunlight direct and rainwater infiltration during outdoor installation to cause battery damage.
- (3) Do not place metal products near the place of the energy storage LiFePO₄ battery installation to prevent short circuits.
- (4) Virtual connection points and corroded wires may generate high heat, and the molten insulation layer will burn surrounding materials and even cause a fire. Therefore, it must be ensured that the connector has been tightened and the wires should be secured with cable ties to avoid loosening of the connector due to shaking during mobile applications.
- (5) After the battery switch is turned off, there is still high voltage inside the energy storage case. Please do not open or touch the internal components, and external short circuit is strictly prohibited.
- (6) Please do not install it in a harsh environment where a large amount of damp, greasy, flammable and explosive dust gathers.
- (7) It is forbidden to reverse the charging and discharging terminals of the battery, other wise it is very easy to damage the battery or cause unpredictable risks.
- (8) When the fan is working, please do not touch it to avoid injury.
- (9) When installing the battery on the wall, you must first ensure the bearing capacity of the wall and check whether the screws are installed firmly to avoid unnecessary danger.
- (10) If an injury occurs during installation or use, please seek medical attention in time.

3.2 Installation and connection

Installation and connection must comply with national and local electrical code requirements. According to the current situation, firstly, choose the corresponding wire or a wire with a larger wire diameter to avoid unnecessary troubles during use. Secondly, determine the installation location. Thirdly, when installing, please make sure to leave at least 200 mm of space at the air outlets on both sides of the energy storage battery to ensure natural convection heat dissipation.

3.3 Schematic diagram of the wall mounted installation

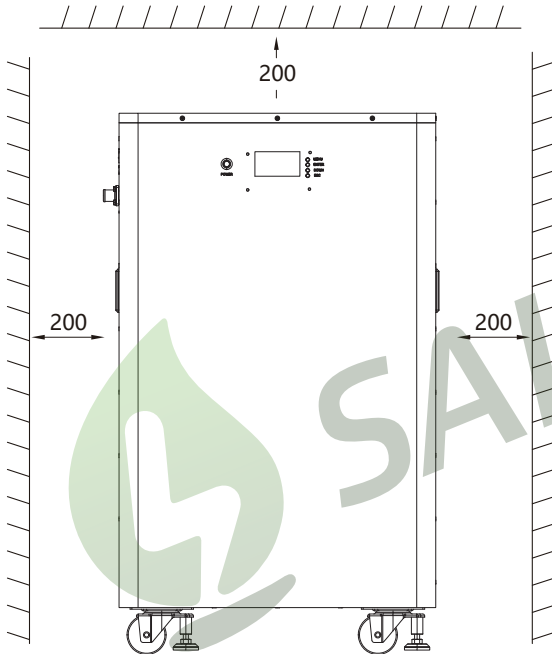

Warning: Danger of explosion! In order to avoid accidents, do not reverse connect the charging and discharging ports or short circuit, and do not install them in a closed environment. Rain proof and moisture-proof protection must be installed in the outdoor.

Attention!! The above steps can be omitted without wall mounting.

Attention!! When Only one battery is using inverter below 5kw or other loads below 5kw are recommended.

Attention!! Before making the final DC connection, please ensure that the battery switch / DC circuit breaker is disconnected, and ensure that the positive (+) must be connected to the negative positive(+), and the negative (-) must be connected to the negative(-).

3.4 Recommended external wiring diameter and switch selection.

Model	Recommended external wiring diameter	Battery continuous current circuit breaker
51.2V280Ah	50mm ² /1AWG	200A/Combiner box
51.2V314Ah	50mm ² /1AWG	200A/Combiner box

Note: The wiring diameter is for reference only. If the distance between the load and the battery is relatively long, use a larger wire to reduce the voltage and improve the system performance. The above wiring diameter and circuit breaker are only recommendations, please follow the actual choose the appropriate wire diameter and circuit breaker according to the situation.

4. Schematic diagram of connecting

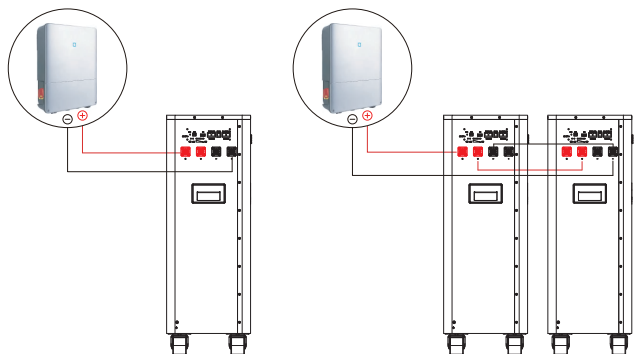

① One unit product

② Two units products

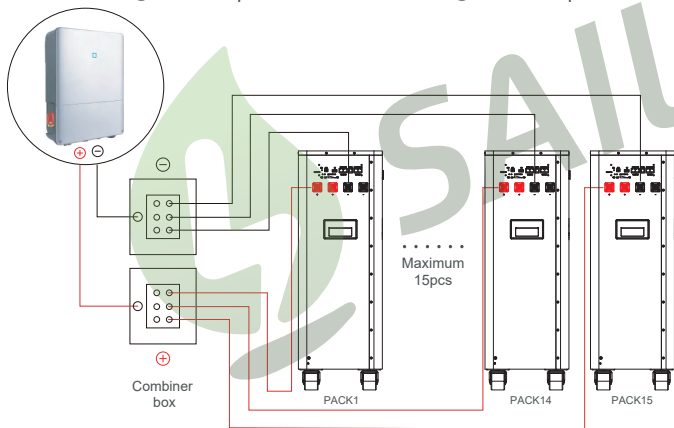

③ More than Two units products

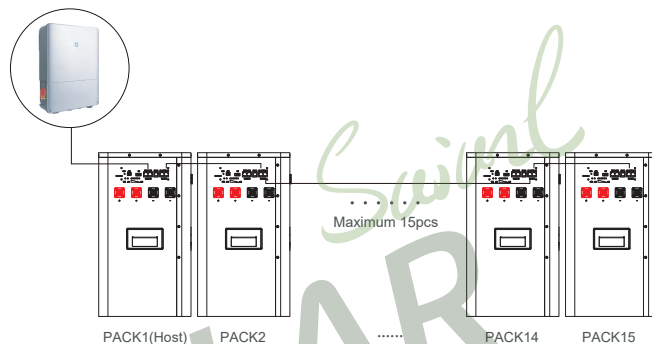

④ Batteries are connected in communication

Note: 1. When the battery pack is used in parallel, it is necessary to distinguish different packs by hardware address, and the hardware address of each pack in the whole battery pack is unique.

2. It must set up a host pack for the battery pack. The inverter communicate with host pack via RS485/CAN. The hardware address can be set successively through the dial switch on the board.

3. After the battery connected to the inverter, turn on the inverter for 5 minutes before turning on the battery, to prevent the BMS being burned out by the excessive surge voltage of the inverter.

Recommended setting data of inverter:

Battery model	LiFePO4/Lithium battery
Model	51.2V280Ah / 51.2V314Ah
Discharge cut-off voltage	43
Over discharge recovery	48
Normal charging voltage	58
Surge charging voltage	60
Overvoltage protection	58.4
Overvoltage recovery	56

5. LED instructions

Table1 LED working status indication

State	normal/warning/protect	RUN	ALM	Battery indicator LED				illustrate
		●	●	●	●	●	●	
Shutdown	hibernate	extinguish	extinguish	extinguish	extinguish	extinguish	extinguish	annihilate
Standby	normal	flash 1	extinguish	According to the battery indicator				standby mode
	alert	flash 1	flash 3					Module low voltage
Charge	normal	Always bright	extinguish	According to the battery indicator				Maximum battery LED flashes Move (flashing 2), overcharge warning ALM does not flash during alarm If there is no utility power, indicate Light goes to standby
	alert	Always bright	flash 3	(battery indication maximum LED flashes 2)				
	Overcharge protection	Always bright	extinguish	Always bright	Always bright	Always bright	Always bright	
	temperature, overcurrent, Failsafe	extinguish	Always bright	extinguish	extinguish	extinguish	extinguish	
Discharge	normal	flash 3	extinguish	According to the battery indicator				stop charging
	alert	flash 3	flash 3					
	Undervoltage protection	extinguish	extinguish	extinguish	extinguish	extinguish	extinguish	stop charging
	temperature, overcurrent, short circuit, Reverse connection, failsafe	extinguish	Always bright	extinguish	extinguish	extinguish	extinguish	stop charging
Invalid		extinguish	Always bright	extinguish	extinguish	extinguish	extinguish	Stop charging and discharging

Table2 Description of capacity indication

state	capacity indicator	Charge				discharge			
		L4 ●	L3 ●	L2 ●	L1 ●	L4 ●	L3 ●	L2 ●	L1 ●
Battery (%)	0~25%	extinguish	extinguish	extinguish	extinguish	extinguish	extinguish	extinguish	constant
	25~50%	extinguish	flash 2	flash 2	constant	extinguish	extinguish	constant	constant
	50~75%	flash 2	flash 2	constant	constant	extinguish	constant	constant	constant
	75~100%	flash 2	constant	constant	constant	constant	constant	constant	constant
Running lights		constant				Blink (blink 3)			

Table 3 LED flashing description

flashing method	Bright	extinguish
flash 1	0.25S	3.75S
flash 2	0.5S	0.5S
flash 3	0.5S	1.5S

Remarks: The LED indicator alarm can be enabled or disabled through the host computer, and the factory default is enabled.

◆ Key Description

1. When the BMS is in sleep state, press the button (3~6S) and release it, the protection board will be activated, and the LED indicators will light up sequentially from "RUN" for 0.5 seconds.
2. When the BMS is active, press the button (3~6S) and release it, the protection board will be put to sleep, and the LED indicators will light up sequentially for 0.5 seconds from the lowest battery indicator.
3. When the BMS is active, press the button (6~10S) and release it, the protection board will be reset, and all the LED lights will light up at the same time for 1.5 seconds.
4. After the BMS is reset, the parameters and functions set by the host computer are still retained. If it is necessary to restore the initial parameters, it can be achieved through the "restore default value" of the host computer, but the relevant operation records and stored data remain unchanged (such as power, cycle times, etc.).

6. BMS communication settings

6.1 BMS communication and setting

When the load (such as inverter) needs to communicate with the battery, in order to establish normal communication with the load, BMS needs to set the following settings for each brand. The RS485/CAN communication protocols of inverters are different, but there are several RS485/CAN communication protocols inside the inverter to match the battery. When using, you can directly select the communication protocol code in the inverter for matching. If you have other problems, please consult the supplier.

Battery BMS interface pin foot definition as shown in the following figure

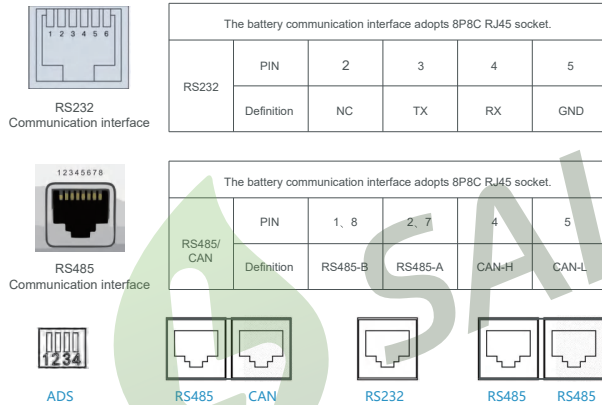

- ◆ "ADS" is used for parallel use of battery packs. PACK can be distinguished by hardware address. The definition of ADS master-slave address refers to communication address selection specification.
- ◆ "RS232" it can monitor the single pack information by computer.
- ◆ "RS485/RS485" is used in parallel for battery pack, and the main communicates with pack from the interface.
- ◆ "RS485/CAN" battery pack can communicate with the inverter through this interface.

6.2 Communication address selection specification

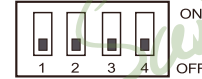

Address	Code switch position				Illustrate
	1#	2#	3#	4#	
0	OFF	OFF	OFF	OFF	Stand-alone use, no cascade
1	ON	OFF	OFF	OFF	Set to Pack 1 (Host)
2	OFF	ON	OFF	OFF	Set to Pack 2
3	ON	ON	OFF	OFF	Set to Pack 3
4	OFF	OFF	ON	OFF	Set to Pack 4
5	ON	OFF	ON	OFF	Set to Pack 5
6	OFF	ON	ON	OFF	Set to Pack 6
7	ON	ON	ON	OFF	Set to Pack 7
8	OFF	OFF	OFF	ON	Set to Pack 8
9	ON	OFF	OFF	ON	Set to Pack 9
10	OFF	ON	OFF	ON	Set to Pack 10
11	ON	ON	OFF	ON	Set to Pack 11
12	OFF	OFF	ON	ON	Set to Pack 12
13	ON	OFF	ON	ON	Set to Pack 13
14	OFF	ON	ON	ON	Set to Pack 14
15	ON	ON	ON	ON	Set to Pack 15

7. LCD screen description

1. Boot page

After the power on/sleep is activated, the welcome interface will be displayed, as shown in the following figure.

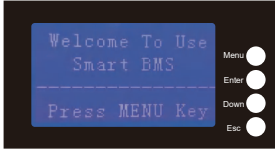

2. Main menu page

Press the menu key to enter the main menu page, as shown in the following figure.

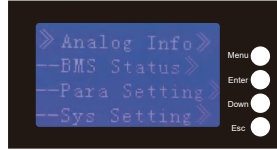

3. Battery parameter collection page

When the cursor points to "battery parameter acquisition", press enter to enter the "battery parameter" acquisition page, as shown in the following figure.

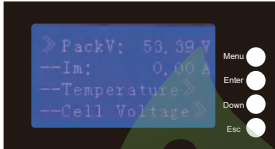

4. Battery status page

When the cursor points to "battery state", press the ENTER button to enter the battery status page, as shown in the following figure.

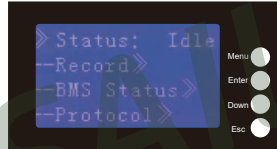

5. Key description

- (1) SW1---- MENU, SW2--- ENTER, SW3---DOWN, SW4--- ESC.
- (2) Every item will use the "»" or "-" to start, "»" means the current cursor position, press DOWN move the cursor position up and down. Items ending with "»" indicate that the item has contents not displayed. Press enter to enter the corresponding page.
- (3) Press ESC to return to the previous directory. Press the menu key anywhere to return to the main menu page.
- (4) In the sleep state, press any key to activate the display screen.

6. Sleep/Shutdown

In the normal operation state, the system will enter the sleep/shutdown state after 1 minute without key operation. In the sleep state, operate any key and the display screen will be activated.

7. All date of LCD display

```

Pack message》 Pack V:
                Pack C: "_": discharging
                "+": charging
                "0": stand by
Battery temp》 Temp1:
                Temp2:
                Temp3:
                Temp4:
                PCB temp:
                EV temp:
Battery vol》  Vol 01:
                Vol 02:
                Vol 16:
Battery cap》  SOC:
                Full Cap:
                Sur Cap:
                Cyc Indx:
Pack status》 Run mode: Charging or discharging
                Abnormal》 Short Num:
                                Temp Pro:
                                Over C Pro:
                                Low V Pro:
                                Over V Num:
                                HT Alarm:
                                HT Pro:
                                HV Alarm:
                                LV Alarm:
                                LV Pro:
                                HC Aarm:
                                HC Pro:
                                Short Pro:
                                Fail Tro:
                status》
Argument tset》 --Not manufacturer. Cannot use.
                system set》 --Baud rate: 9600
    
```

8. Technical parameter list

Contact sales person to get the latest parameters of SAIL SOLAR.

9. Maintenance and conservation

Item	Problem description	Description/possible causes	Solution
1	Unable to boot properly, BMS will immediately enter the protect ion state after press the switch	The external load does not match, and the instantaneous current of load startup is too large	1. Press the on key to restart 2. Reduce load power
2	Automatically disconnect the output during use	1. The battery voltage is too low 2. Output or load short circuit	1. Charge the battery 2. Disconnect the load and restart the battery
3	The Communication fault occurs when the load is inverter	1. Communication line connection error (connecting pin improper connection or oxidation) 2. The internal protocol code of inverter is not properly chosen 3. Communication insert loose or improper connection	1. Check the connection between BMS and inverter 2. Choose the corresponding communication protocol in the inverter's internal program 3. Reconnect the communication cables. If the problem still-exists please contact the manufacturer
4			
5			
6			

In order to maintain the best and long-term performance, the following items are recommended to be inspected twice a year.

1. Confirm that the surrounding air flow will not be blocked, and remove any dirt and debris on the cooling hole.
2. Check all exposed wires, shabby and damage, please place or repair them if necessary.
3. If it is not used for a long time, it is recommended to charge it every three months.



Danger of electric shock! Make sure that the power supply has been disconnected during the above operations, and then carry out corresponding inspection and operation.

10. Warranty record card

Dear Customers:

Hello! Thank you very much for purchasing our products. In order to serve you better, please read and fill in and keep this warranty card after purchasing the product. In order to avoid your worries, our company here by makes a warranty service commitment and provides standardized after sales service accordingly.

Exemption of warranty liability scope:

1. Damage caused by man-made or other natural disasters.
2. Failure caused by incorrect operation and installation or use in an environment other than the product's prescribed use.
3. Damage caused by unauthorized disassembly and modification.

Contact: _____ Number: _____

Tel: _____ Email: _____

Purchase date: _____

Address: _____

Maintenance records			
Repair Date	Repair content	Repair Person	remark