

USER MANUAL

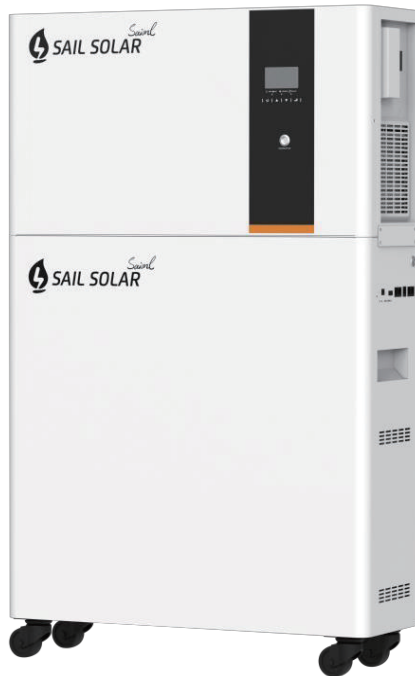

**Energy Storage Controller
Inverter Integrated Machine
(6.2kW 15.36kWh)**

Preface

First of all, thank you for purchasing our Energy Storage Controller Inverter Integrated Machine! This manual introduces the functional characteristics and usage of Energy Storage Controller Inverter Integrated Machine, including product parameters, installation and commissioning, fault maintenance check, etc. Please ensure you read this manual carefully before use.

Attention





- No direct sunlight
- No rain
- Do not cover the device
- Keep away from heat and fire
- Please read the corresponding warning signs and the corresponding battery type specifications carefully before installing and using the equipment.
- Do not disassemble the equipment, if you need equipment repair and maintenance, please go to the designated maintenance center, Improper operation could lead to electric shock or even fire.
- To reduce the risk of electric shock, disconnect all circuits before performing repairs and maintenance.
- Warning: The battery must be installed by a professional technician.
- For maximum product functionality and efficiency, please configure the cable type as specified in the product.
- Please be careful to use metal tools for loading and unloading work to avoid short circuit and explosion caused by metal conductors.
- Equipment grounding requirements: Please select a permanently fixed place for product wiring!
- Do not short-circuit the AC output and DC input. Do not connect the power supply when the DC input is short-circuited.
- Warning! Only professional technicians can service the equipment. If there is still an error after following the troubleshooting table, please contact our regional agents or contact our customer service center directly.
- When the ambient temperature exceeds 45°C and above, the machine will automatically reduce the power, please pay attention to the ambient temperature change!

Table of Contents









Chapter 1 Safety Information and Precautions	1
Chapter 2 Product Information	3
2.1 Introduction.....	3
2.2 Functional Features	3
2.3 System schematic	3
2.4 Product Size	4
Chapter 3 Energy Storage Inverter Product Introduction	5
3.1 Product Size	5
3.2 Interface Description	5
3.3 Connection	6
3.4 OPERATION	8
3.4.1 Power ON/OFF	8
3.4.2 Operation and Display Panel.....	8
3.4.3 LED Indicator	8
3.4.4 Function Keys	9
3.5 LCD Setting	9
3.5.1 Setting Programs	9
3.6 BATTERY EQUALIZATION	15
3.7 SETTING FOR LITHIUM BATTERY	17
3.8 Fault Reference Code	22
3.9 Warning Indicator	23
3.10 SPECIFICATIONS.....	24
3.11 TROUBLE SHOOTING	27
Chapter 4 Storage Battery Introduction.....	29
4.1 Appearance is introduced	29
4.2 Technical Specifications.....	30
4.3 Comparison table of DIP switch settings	31
4.4 LED indicator description	32
4.5 Safety and precautions	34





Chapter 1 Safety Information and Precautions

Safety Definition: In this manual, safety precautions are divided into the following two categories:

-  **Danger:** A situation in which serious injury, or even death, may result from a hazard caused by failure to operate as required;
-  **Caution:** Hazards caused by failure to operate as required, which may result in moderate injuries or minor injuries, and equipment damage;

Please read this chapter carefully when installing, commissioning and maintaining this system, and be sure to follow the safety precautions required by the contents of this chapter. Any injury or loss caused by irregular operation is not the responsibility of our company.

Usage Stage	Security Level	Item
Before installation	 Danger	<ul style="list-style-type: none"> ➢Do not install the equipment if you find water, missing parts or damaged parts when you open the box! ➢If the packing list does not match the actual name, please do not install it!
	 Attention	<ul style="list-style-type: none"> ➢Handling should be done gently, otherwise there is a risk of damage to the equipment! ➢Please do not use equipment with damage or missing parts. There is a risk of injury! ➢Do not touch the components in the equipment with your hands, otherwise there is a risk of electrostatic damage!
At installation	 Danger	<ul style="list-style-type: none"> ➢Please install on metal and other flame retardant objects; keep away from combustible materials. Otherwise it may cause fire! ➢Do not unscrew the fixing bolts of the equipment components at will.
	 Attention	<ul style="list-style-type: none"> ➢You can't just open the device case! ➢Please install the equipment in a place with little vibration and avoid direct sunlight.
Wiring time	 Danger	<ul style="list-style-type: none"> ➢The instructions in this manual must be followed and the work performed by professional electrical engineers, otherwise unexpected dangers can occur!
	 Attention	<ul style="list-style-type: none"> ➢Pay attention to the markings of the terminals, do not connect the wrong line! Otherwise cause equipment damage! ➢Please refer to the recommendations in the manual for the wire diameter of the wire used. Otherwise accidents may occur!
Before power on	 Danger	<ul style="list-style-type: none"> ➢Please confirm whether the voltage level of the input power supply is the same as the rated voltage level of this equipment; whether the wiring of the terminals is correct; and check whether there is a short circuit in the peripheral circuit connected with this equipment and whether the connected lines are tight, otherwise it will cause damage to the equipment! ➢Any part of the equipment does not need to be tested for voltage resistance, the product has been tested at the factory. Otherwise it will cause an accident!
	 Attention	<ul style="list-style-type: none"> ➢The wiring of all peripheral accessories must comply with the instructions in this manual and be wired correctly according to the circuit connection method provided in this manual. Otherwise cause an accident!

Usage Stage	Security Level	Item
After power on	 Danger	<ul style="list-style-type: none"> ➤ Do not open the cover after the power is applied. Otherwise there is a risk of electric shock! ➤ Do not touch the equipment and surrounding circuits with wet hands. Otherwise there is a risk of electric shock! ➤ Do not touch any input and output terminals of the device. Otherwise there is a risk of electric shock!
	 Attention	<ul style="list-style-type: none"> ➤ Please do not change the manufacturer's parameters of the equipment at will. Otherwise, damage to the equipment may result!
In operation	 Danger	<ul style="list-style-type: none"> ➤ Non-technical professionals should not test the signal while the equipment is in operation. Otherwise it may cause personal injury or equipment damage!
	 Attention	<ul style="list-style-type: none"> ➤ When the equipment is running, avoid having something fall into the equipment. Otherwise cause damage to the equipment! ➤ Do not start and stop the equipment frequently, otherwise it will cause damage to the equipment!
Maintenance time	 Danger	<ul style="list-style-type: none"> ➤ Do not perform maintenance and repair on the equipment without professional training. Otherwise, personal injury or equipment damage will result! ➤ Please do not carry out maintenance and repair of the equipment with electricity. Otherwise there is a risk of electric shock! ➤ Make sure that the input power of the equipment is disconnected for 10 minutes before implementing maintenance and repair of the equipment, and pay attention to the residual charge on the capacitor when maintenance will cause harm! ➤ All pluggable plug-ins must be plugged in the case of power failure!

Chapter 2 Product Information

2.1 Introduction

The Energy Storage Controller Inverter Integrated Machine combines the functions of inverter, MPPT solar controller and utility charging to provide stable power supply for power-using equipment in areas with no power, lack of power and unstable power. The product is based on a fully digital intelligent design with advanced SPWM technology, outputting pure sine wave, converting DC power into AC power, suitable for AC loads such as household appliances, power tools, industrial equipment, electronic video and audio. LCD screen display design, real-time display of system operation data and operating status. Comprehensive electronic protection function ensures the whole system is safer and more stable.

2.2 Functional Features

- Pure sine wave inverters;
- Integrated MPPT controller/charger;
- Settable priority of utility and PV power supply;
- Wide PV input voltage;
- Settable battery type, supporting lead-acid and lithium batteries;
- Functions and parameters can be set via the LCD;
- With battery equalization function to optimize battery performance and extend battery life.

2.3 System schematic

The following figure shows the system application scenario of this product. A complete system includes the following parts:

- 1. Photovoltaic module:** Convert light energy into DC electric energy, charge the battery through energy storage inverter, or directly reverse it into AC to power the load.
- 2. Utility or generator:** Connected at the AC input, it can supply power to the load and charge the battery at the same time. If no utility or generator is connected, the system can also operate normally, when the load power is provided by the battery and PV module.
- 3. Battery:** The role of the battery is to ensure the normal use of power for the system load when the solar energy is insufficient and there is no utility power.
- 4. Household load:** It can access various household and office loads, including refrigerators, lamps, TV sets, fans, air conditioners and other AC loads.
- 5. Energy Storage Controller Inverter Integrated Machine:** The energy conversion device of the whole system.

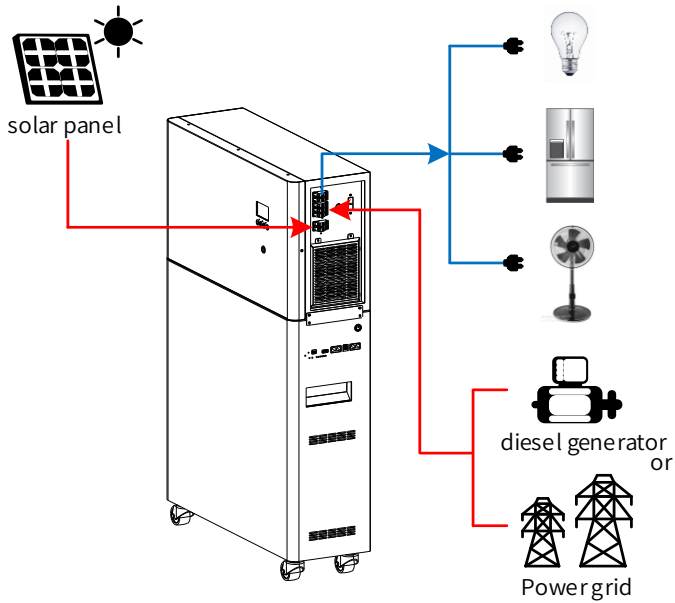

System schematic

2.4 Product Size

(Unit: mm)

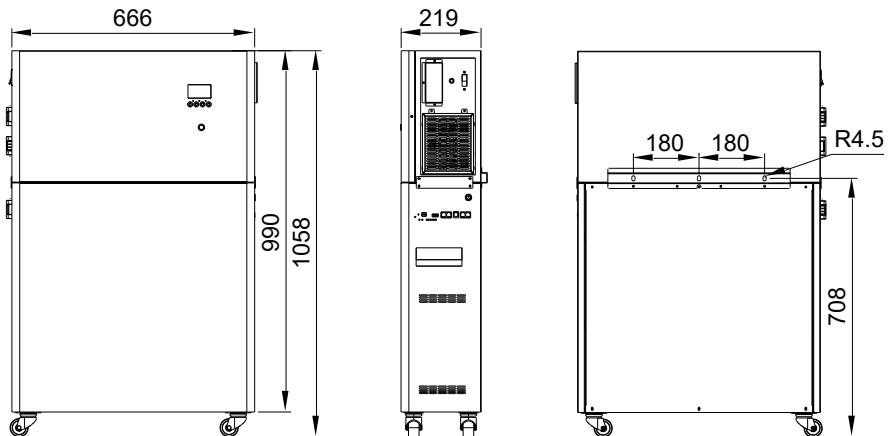

Chapter 3 Energy Storage Inverter Product Introduction

3.1 Product Size

(Unit: mm)

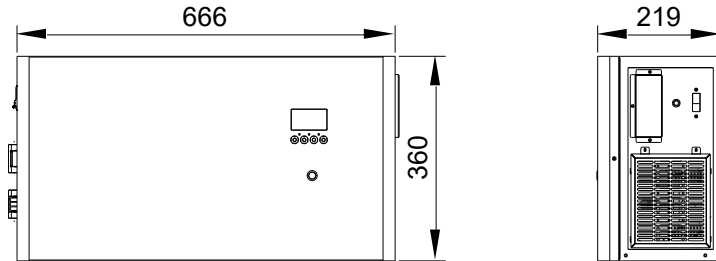

3.2 Interface Description

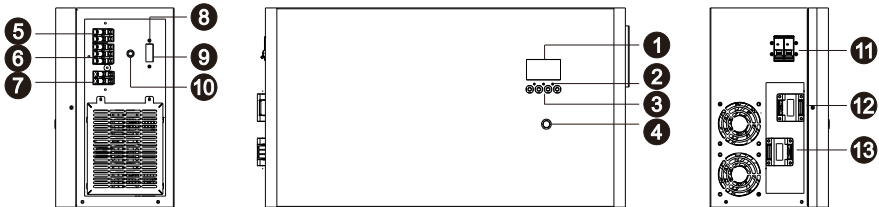

- | | |
|-------------------------------|--------------------------------|
| 1. LCD display | 8. BMS communication interface |
| 2. Indicator | 9. COM communication interface |
| 3. Function button | 10. Overload protector |
| 4. Power switch | 11. Battery switch |
| 5. load output interface | 12. Battery negative |
| 6. grid-power input interface | 13. Battery positive |
| 7. PV connectors | |

3.3 Connection

Step 1: Wiring

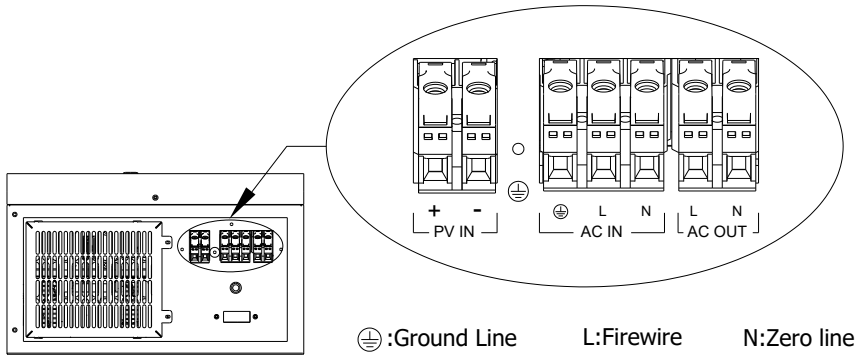

■ AC input/output wiring method:

- 1) Disconnect the external circuit breaker before wiring the AC input/output, and verify that the cable used is thick enough;
- 2) According to the cable order and terminal position shown below, correctly connect the AC input line, please ground the wire first, then connect the fire wire and zero wire.

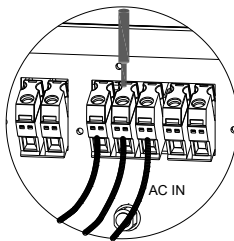

- 3) According to the cable order and terminal position shown below, correctly connect the AC output line, please ground the wire first, then connect the fire wire and zero wire.

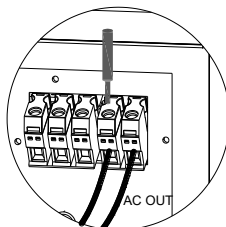

Note: The grounding cable should be as thick as possible (wire cross-sectional area not less than 4mm²), the grounding point should be as close as possible to the energy storage inverter, and the shorter the grounding wire, the better.

■ PV input wiring method:

- 1) Disconnect the external circuit breaker before wiring and verify that the cable used is thick enough;
- 2) Connect the PV input wires correctly according to the cable sequence and terminal locations shown in the figure below.

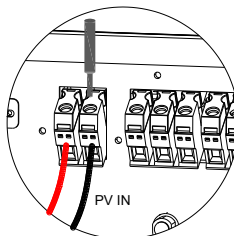

 **Warning:**

- 1) Utility input, AC output and PV arrays can generate very high voltages; be sure to disconnect the circuit breaker or fuse before wiring;
- 2) During the wiring process, be sure to disconnect the circuit breaker or fuse, and make sure that the "+" and "-" pole leads of each component are connected correctly; a circuit breaker must be installed at the battery end. Before wiring, be sure to disconnect the circuit breaker to prevent strong electrical sparks during wiring and to avoid battery short circuit during wiring; if the energy storage inverter is used in the area with frequent lightning, it is recommended to install an external lightning arrester at the PV input.

Step 2: Check whether the wiring is connected correctly and firmly, especially check whether the battery input is reversed, the PV input is reversed, and whether the AC input is incorrectly connected to the AC output.

Step 3: Start the energy storage inverter

Firstly, close the circuit breaker of the battery, secondly, press the circular switch on the front of the machine, the display "AC OUTPUT" has a numerical display, which means that the inverter is working normally, then close the circuit breaker of PV array and utility, finally, after the AC output is normal, then open the AC load one by one, so as to avoid the large instantaneous shock caused by turning on the load at the same time. The energy storage inverter will work normally according to the set mode.

Note: If supplying power to different AC loads, it is recommended to turn on the load with high inrush current first, and then turn on the load with low inrush current after the load has been working stably.

Note: If the energy storage inverter does not work properly or if the LCD or indicator shows abnormal, Refer to Troubleshooting.

3.4 OPERATION

3.4.1 Power ON/OFF

Once the unit has been properly installed and the batteries are connected well, simply press power switch to turn on the unit.

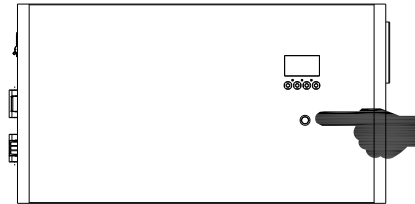

3.4.2 Operation and Display Panel

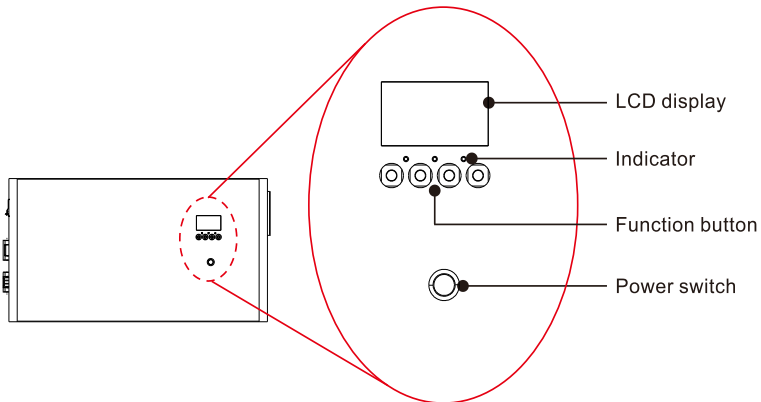

The operation and display panel, shown in above chart, is on the front panel of the inverter. It includes three indicators, a power switch, four function keys and a LCD display, indicating the operating status and input/output power information.

3.4.3 LED Indicator

LED Indicator		Messages	
AC / INV	Green	Solid On	Output is powered by utility in Line mode.
		Flashing	Output is powered by battery or PV in battery mode.
CHG	Green	Solid On	Battery is fully charged.
		Flashing	Battery is charging.
FAULT	Red	Solid On	Fault occurs in the inverter.
		Flashing	Warning condition occurs in the inverter.

3.4.4 Function Keys

Function Key	Description
ESC	To exit setting mode
UP	To go to previous selection
DOWN	To go to next selection
ENTER	To confirm the selection in setting mode or enter setting mode







3.5 LCD Setting

After pressing and holding ENTER button for 3 seconds, the unit will enter setting mode. Press "UP" or "DOWN" button to select setting programs. And then, press "ENTER" button to confirm the selection or ESC button to exit.

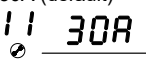

3.5.1 Setting Programs

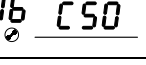
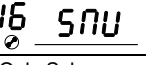
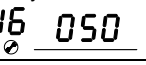
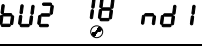
Program	Description	Selectable option	
01	Output source priority: To configure load power source priority	Utility first (default) 	Utility will provide power to the loads as first priority. Solar and battery energy will provide power to the loads only when utility power is not available.
		Solar first 	Solar energy provides power to the loads as first priority. If solar energy is not sufficient to power all connected loads, battery energy will supply power the loads at the same time. Utility provides power to the loads only when any one condition happens: Solar energy is not available Battery voltage drops to either low-level warning voltage or the setting point in program 12.
		SBU priority 	Solar energy provides power to the loads as first priority. If solar energy is not sufficient to power all connected loads, battery energy will supply power to the loads at the same time. Utility provides power to the loads only when battery voltage drops to either low-level warning voltage or the setting point in program 12.
		SUB priority 	Solar energy is charged first and then power to the loads. If solar energy is not sufficient to power all connected loads, Utility energy will supply power to the loads at the same time. Note: SUB priority is just for PVmax.=500VDC model.
02	Maximum charging current: To configure total charging current for solar and utility chargers.	50A (default) 	If selected, acceptable charging current range will be from Max. AC charging current to Max. charging current of SPEC, but it shouldn't be less than the AC charging

Program	Description	Selectable option	
	(Max. charging current = utility charging current + solar charging current)		current(program 11)
03	AC input voltage range	Appliances (default) 03 <u>APL</u>	If selected, acceptable AC input voltage range will be within 110-280VAC.
		UPS 03 <u>UPS</u>	If selected, acceptable AC input voltage range will be within 170-280VAC.
		Generator 03 <u>GNt</u>	If selected, acceptable AC input voltage range will be within 170-280VAC and compatible with generators. Note: Because generators are unstable, maybe the output of inverter will be unstable too.
05	Battery type	AGM (default) 05 <u>AGn</u>	Flooded 05 <u>FLd</u>
		User-Defined 05 <u>USE</u>	If "User-Defined" is selected, battery charge voltage and low DC cut-off voltage can be set up in program 26, 27 and 29.
		05 <u>L12</u>	Support PYLON US2000 Protocol 3.5 Version
		05 <u>L14</u>	Standard communication Protocol form inverter supplier
06	Auto restart when overload occurs	Restart disable 06 <u>Ltd</u>	Restart enable (default) 06 <u>LtE</u>
07	Auto restart when over temperature occurs	Restart disable 07 <u>ttd</u>	Restart enable (default) 07 <u>tE</u>
08	Output voltage	220V 08 <u>220</u> v	230V (default) 08 <u>230</u> v
		240V 08 <u>240</u> v	
09	Output frequency	50Hz (default) 09 <u>50</u> Hz	60Hz 09 <u>60</u> Hz
10	Auto bypass When selecting "auto", if the mains power is normal, it will automatically bypass, even if the switch is off.	manual(default) 10 <u>nNL</u>	auto 10 <u>AtO</u>

Program	Description	Selectable option	
11	Maximum utility charging current	30A (default)  If selected, acceptable charging current range will be within 2A-Max. AC charging current.	
12	Setting voltage point back to utility source when selecting "SBU priority" or "Solar first" in program 01.	48V models: 46V (default) 	Setting range is from 44.0V to 57.2V for 48V model, but the max setting value must be less than the value of program13.
		24V models: 23V (default) 	Setting range is from 22.0V to 28.6V for 24V model, but The max setting value must be less than the value of program13.
13	Setting voltage point back to battery mode when selecting "SBU priority" or "Solar first" in program 01.	Battery fully charged (default)  48V models: Setting range is from 48V to full (the value of program26-0.4V), but the max setting value must be more than the value of program12. 24V models: Setting range is from 24V to full (the value of program26-0.4V), but the max setting value must be more than the value of program12.	
16	Charger source priority: To configure charger source priority	If this inverter/charger is working in Line, Standby or Fault mode, charger source can be programmed as below:	
		Solar first 	Solar energy will charge battery as first priority. Utility will charge battery only when solar energy is not available.
		Solar and Utility (default) 	Solar energy and utility will charge battery at the same time.
		Only Solar 	Solar energy will be the only charger source no matter utility is available or not.
		If this inverter/charger is working in Battery mode or Power saving mode, only solar energy can charge battery. Solar energy will charge battery if it's available and sufficient.	
18	Buzzer mode	Mode1 	Buzzer mute
		Mode2 	The buzzer sounds when the input source changes or there is a specific warning or fault
		Mode3 	The buzzer sounds when there is a specific warning or fault

Program	Description	Selectable option	
		Mode4(default) bU2 18 rd4	The buzzer sounds when there is a fault
19	Auto return to default display screen	Return to default display screen (default) 19 ESP	If selected, no matter how users switch display screen, it will automatically return to default display screen (Input voltage /output voltage) after no button is pressed for 1 minute.
		Stay at latest screen 19 HEP	If selected, the display screen will stay at latest screen user finally switches.
20	Backlight control	Backlight on (default) 20 LON	Backlight off 20 LOF
23	Overload bypass: When enabled, the unit will transfer to line mode if overload occurs in battery mode.	Bypass disable 23 bYd	Bypass enable(default) 23 bYE
25	Modbus ID Setting	Modbus ID Setting Range : 001(default)~247 nd 25 001	
26	Bulk charging voltage (C.V voltage)	48V models default setting: 56.4V CU 26 56.4 ^{BATT} v	
		24V models default setting: 28.2V CU 26 28.2 ^{BATT} v	
		If self-defined is selected in program 5, this program can be set up. Setting range is from 24.0V to 30.0V for 24V model and 48.0V to 62.0V for 48V model. But the setting value must be more than or equal the value of program27. Increment of each click is 0.1V.	
27	Floating charging voltage	48V models default setting: 54.0V FLU 27 54.0 ^{BATT} v	
		24V models default setting: 27.0V FLU 27 27.0 ^{BATT} v	
		If self-defined is selected in program 5, this program can be set up. Setting range is from 24.0V to the value of program 26 for 24v model and 48.0V to the value of program 26 for 48v model. Increment of each click is 0.1V.	
29	Low DC cut-off voltage	48V models default setting: 42.0V COV 29 42.0 ^{BATT} v	

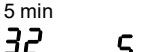
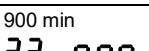
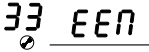
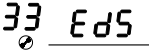
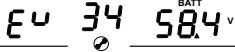
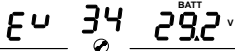
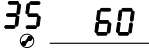
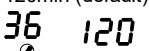
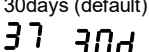
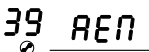
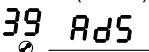
Program	Description	Selectable option	
		24V models default setting: 21.0v 	
		If self-defined is selected in program 5, this program can be set up. Setting range is from 20.0V to 27.0V for 24V model and 40.0V to 54.0V for 48V model. The setting value must be less than the value of program12. Increment of each click is 0.1V. Low DC cut-off voltage will be fixed to setting value no matter what percentage of load is connected.	
32	Bulk charging time (C.V stage)	Automatically (Default): 	If selected, inverter will judge this charging time automatically.
		5 min 	The setting range is from 5 min to 900 min. Increment of each click is 5 min.
		900 min 	
		If "USE" is selected in program 05, this program can be set up.	
33	Battery equalization	Battery equalization 	Battery equalization disable (default) 
		If "Flooded" or "User-Defined" is selected in program 05, this program can be set up.	
34	Battery equalization voltage	48V models default setting is 58.4V. Setting range is from 48V ~ 64V. Increment of each click is 0.1V. 	
		24V models default setting is 29.2V. Setting range is from 24V ~ 30V. Increment of each click is 0.1V. 	
35	Battery equalized time	60min (default) 	Setting range is from 0 min to 900min. Increment of each click is 5min.
36	Battery equalized timeout	120min (default) 	Setting range is from 0 min to 900 min. Increment of each click is 5min.
37	Equalization interval	30days (default) 	Setting range is from 1 to 90 days. Increment of each click is 1 day
39	Equalization activated immediately	Enable 	Disable (default) 
		If equalization function is enabled in program 33, this program can be set up. If "Enable" is selected in this program, it's to activate battery equalization immediately and LCD main page will shows "E9". If "Disable" is selected, it will cancel	

Program	Description	Selectable option	
		equalization function until next activated equalization time arrives based on program 37 setting. At this time, "E9" will not be shown in LCD main page.	
41	Automatic activation for lithium battery	ARt (41) nNL	Disable automatic activation
		ARt (41) ALO	When Program05 is selected "Lix" as lithium battery and when the battery is not detected, the unit will activate automatically the lithium battery at a time. If you want to activate automatically the lithium battery, you must restart the unit.
42	Manual activation for lithium battery	nARt (42) NOP	Default: disable activation
		nARt (42) ACT	When Program05 is selected "Lix" as lithium battery, when the battery is not detected, If you want to activate the lithium battery at a time, you could selected it.
43	Setting SOC point back to utility source when selecting "SBU priority" or "Solar first" in program 01	(43) 050% ^{BAT}	Default 50%, 20%~50% Settable
44	Setting SOC point back to battery mode when selecting "SBU priority" or "Solar first" in program 01	(44) 095% ^{BAT}	Default 95%, 60%~100% Settable
45	Low DC cut-off SOC	(45) 020% ^{BAT}	Default 20%, 3%~30% Settable
46	Maximum discharge current protection	ndC (46) OFF	Default OFF Disable current discharge current protection function
		ndC (46) 100	When the mains exists, the battery stops discharging when the discharge current reaches the set value, and the mains supplies power to the load. When mains supply does not exist, an alarm will be raised, but the battery will still discharge. The setting range is from 50A to 500A.

3.6 BATTERY EQUALIZATION

Equalization function is added into charge controller. It reverses the buildup of negative chemical effects like stratification, a condition where acid concentration is greater at the bottom of the battery than at the top. Equalization also helps to remove sulfate crystals that might have built up on the plates. If left unchecked, this condition, called sulfation, will reduce the overall capacity of the battery. Therefore, it's recommended to equalize battery periodically.

● How to Apply Equalization Function

You must enable battery equalization function in monitoring LCD setting program 33 first. Then, you may apply this function in device by either one of following methods:

- 1) Setting equalization interval in program 37.
- 2) Active equalization immediately in program 39.

● When to Equalize

In float stage, when the setting equalization interval (battery equalization cycle) is arrived, or equalization is active immediately, the controller will start to enter Equalize stage.

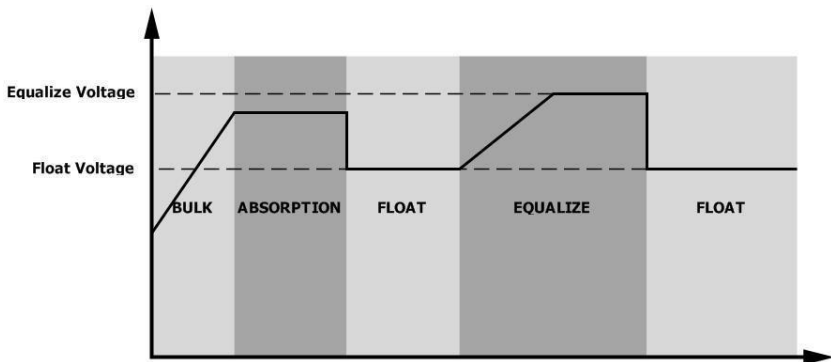

● **Equalize charging time and timeout**

In Equalize stage, the controller will supply power to charge battery as much as possible until battery voltage raises to battery equalization voltage. Then, constant-voltage regulation is applied to maintain battery voltage at the battery equalization voltage. The battery will remain in the Equalize stage until setting battery equalized time is arrived.

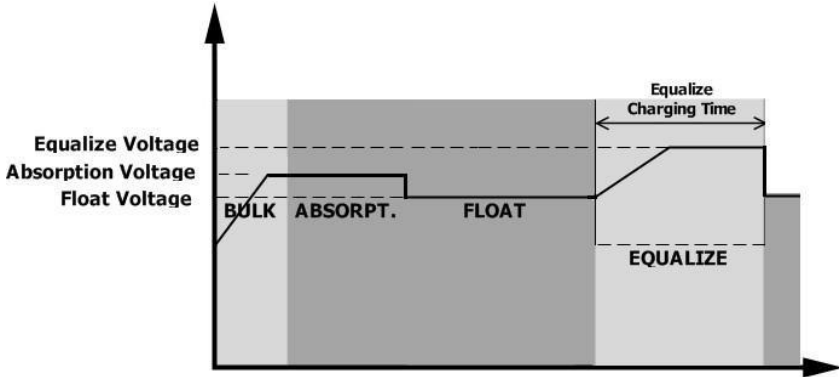

However, in Equalize stage, when battery equalized time is expired and battery voltage doesn't rise to battery equalization voltage point, the charge controller will extend the battery equalized time until battery voltage achieves battery equalization voltage. If battery voltage is still lower than battery equalization voltage when battery equalized timeout setting is over, the charge controller will stop equalization and return to float stage.

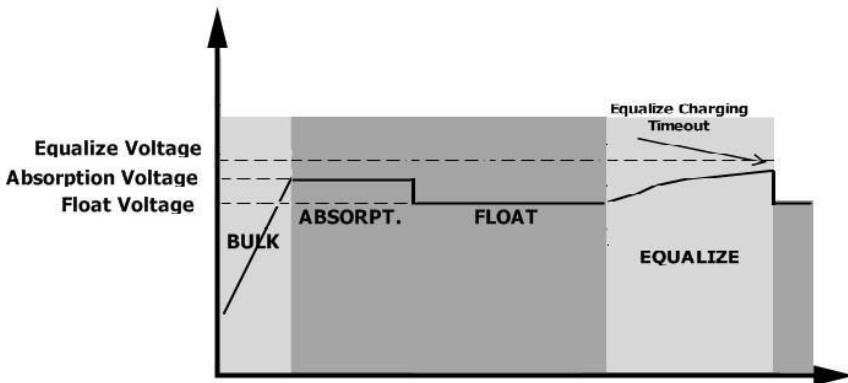

3.7 SETTING FOR LITHIUM BATTERY

1. Lithium Battery Connection

If choosing lithium battery for the inverter, you are allowed to use the lithium battery only which the protocol is allowed to be used. (Support PYLON US2000 Protocol 3.5 Version)

There're two connectors on the lithium battery, RS485 port of BMS and power cable.

Please follow below steps to implement lithium battery connection:

- Assemble battery terminal based on recommended battery cable and terminal size (same as Lead acid, see section Lead-acid Battery connection for details).
- Connect the end of RS485 port of battery to BMS(RS485) communication port of inverter.

2. Lithium battery communication and setting

If choosing lithium battery, make sure to connect the BMS communication cable between the battery and the inverter. This communication cable delivers information and signal between lithium battery and the inverter. This information is listed below:

- Re-configure charging voltage, charging current and battery discharge cut-off voltage according to the lithium battery parameters.
- Have the inverter start or stop charging according to the status of lithium battery.

1) Connect the end of RS485 of battery to RS485 communication port of inverter

Make sure the lithium battery RS485 port connects to the inverter is Pin to Pin, the communication cable is inside of package and the inverter RS485 port pin assignment shown as below:

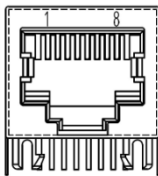

Pin number	RS485 Port
PIN1	RS485-B
PIN2	RS485-A
PIN7	RS485-A
PIN8	RS485-B

2) Communication interface with host computer/monitoring module

Through the RS485 communication port and the optional PC /APP developed by our company, we can monitor the running status of the off-grid energy storage inverter and set relevant parameters on the computer /APP.

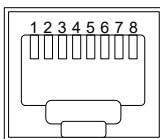

Pin number	RS485 Port
1	RS485-A
2	RS485-B
4	VCC (12V)
8	Gnd

3) LCD setting

After connecting, you need to finish and confirm some settings as follow:

- Select program 05 as lithium battery type.
- Confirm program 41/42/43/44/45 setting value.

Note: Program 43/44/45 are only available with successful communication, they will replace the Program 12/13/29 function, at the same time, program 12/13/29 become unavailable.

4)LCD Display

If communication between the inverter and battery is successful, there is some information showing on the LCD as follow:

Item	Description	LCD display
1	Communication successful icon	<p>will be flashing</p>
2	Max lithium battery charging voltage	<p>Max lithium battery charging voltage is 56.0V.</p>
3	Max lithium battery charging current	<p>Max lithium battery charging current is 40A.</p>
4	Lithium battery discharging is forbidden	<p>Li will flash once every 1 second</p>
5	Lithium battery charging is forbidden	<p>Li will flash once every 2 second</p>
6	Lithium battery SOC(%)	<p>Lithium battery SOC is 63AH and 60%</p>

Remark:

- You'd better to finish setting without turn on the inverter(just let the LCD show, no output);
- When you finish setting, please restart the inverter.

5)Setting for lithium battery

Dip Switch: There are 4 Dip Switches that sets different battery group address. If switch position is turned to the “OFF” position, it means “0”. If switch position is turned to the “ON” position, it means “1”.

Dip 1, 2, 3 and 4 are reserved for battery group address.

NOTE: “1” is upper position and “0” is bottom position.

For the setting of dip switch, please refer to [“4.3 Dip Switch Setting”](#) in the battery introduction.

Process of install

Step 1. Connect the BMS communication port of the inverter and the RS485 port of the battery with the signal cable.

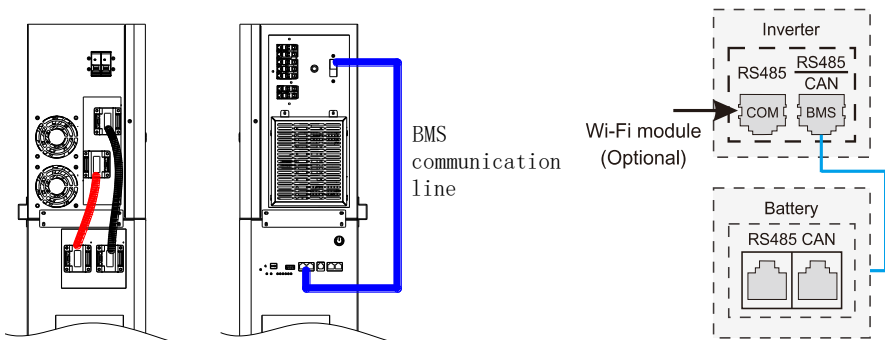

Step 2. Open the side circuit breaker of the inverter.

Step 3. Switch on Lithium battery.

Step 4. Switch on the inverter.

Step 5. Be sure to select battery type as “Li2” in LCD program 5.

If communication between the inverter and battery is successful, the battery **Li** on LCD display will light

6)Setting for lithium battery without communication

This suggestion is used for lithium battery application and avoid lithium battery BMS protection without communication, please finish the setting as follow:

Before starting setting, you must get the battery BMS specification:

- A.Max charging voltage
- B.Max charging current
- C.Discharging protection voltage

1. Set battery type as “USE” (user-defined)

05	Battery type	AGM (default) 05 AGM	Flooded 05 FLD
		User-Defined 05 USE	If “User-Defined” is selected, battery charge voltage and low DC cut-off voltage can be set up in program 26, 27 and 29.

2. Set C.V voltage as Max charging voltage of BMS-0.5V.

26	Bulk charging voltage (C.V voltage)	default setting: 56.4V CU 26 56.4 ^{BATT} v
		If self-defined is selected in program 5, this program can be set up. Setting range is from 24.0V to 30.0V for 24V model and 48.0V to 62.0V for 48V model. But the setting value must be more than or equal the value of program27. Increment of each click is 0.1V.

3. Set floating charging voltage as C.V voltage.

27	Floating charging voltage	default setting: 54.0V FLU 27 54.0 ^{BATT} v
		If self-defined is selected in program 5, this program can be set up. Setting range is from 24.0V to the value of program 26 for 24V model and 48.0V to the value of program 26 for 48V model. Increment of each click is 0.1V.



4. Set Low DC cut-off voltage ≥discharging protection voltage of BMS+2V.

29	Low DC cut-off voltage	default setting: 42.0V COU 29 42.0 ^{BATT} v
		If self-defined is selected in program 5, this program can be set up. Setting range is from 20.0V to 27.0V for 24V model and 40.0V to 54.0V for 48V model. The setting value must be less than the value of program12. Increment of each click is 0.1V.Low DC cut-off voltage will be fixed to setting value no matter what percentage of load is connected.

5. Set Max charging current which must be less than the Max charging current of BMS.

02	Maximum charging current: To configure total charging current for solar and utility chargers. (Max. charging current = utility charging current + solar charging current)	50A (default) 02 50 ^A	If selected, acceptable charging current range will be from Max. AC charging current to Max. charging current of SPEC, but it shouldn't be less than the AC charging current (program 11)
----	---	-------------------------------------	---

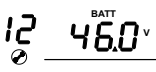















6. Setting voltage point back to utility source when selecting “SBU priority” or “Solar first” in program 01. The setting value must be \geq Low DC cut-off voltage +1V, or else the inverter will have a warning as battery voltage low.





12	Setting voltage point back to utility source when selecting “SBU priority” or “Solar first” in program 01.	Available options in 48V models: 46V (default)
		
		Available options in 24V models: 23V (default)
		

Remark:







- You'd better to finish setting without turn on the inverter(just let the LCD show, no output);
- When you finish setting, please restart the inverter.

3.8 Fault Reference Code

Fault Code	Fault Event	Icon on
01	Over temperature of inverter module	
02	Over temperature of DC/DC module	
03	Battery voltage is too high	
04	Over temperature of PV module	
05	Output short circuited.	
06	Output voltage is too high.	
07	Overload time out	
08	Bus voltage is too high	
09	Bus soft start failed	
10	PV over current	
11	PV over voltage	
12	DC/DC over current	
13	Over current or surge	
14	Bus voltage is too low	
15	Inverter failed (Self-checking)	
18	Op current offset is too high	
19	Inverter current offset is too high	

Fault Code	Fault Event	Icon on
20	DC/DC current offset is too high	
21	PV current offset is too high	
22	Output voltage is too low	
23	Inverter negative power	

3.9 Warning Indicator

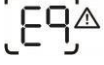
Warning Code	Warning Event	Audible Alarm	Icon flashing
02	Temperature is too High	Beep three times every second	
04	Low battery	Beep once every second	
07	Overload	Beep once every 0.5 second	
10	Output power derating	Beep twice every 3 seconds	
15	PV energy is low	Beep twice every 3 seconds	
19	Lithium Battery communication is failed	Beep once every 0.5 second	
E9	Battery equalization	None	

3.10 SPECIFICATIONS

Table 1 Line Mode Specifications

INVERTER MODEL	6.2kW 48V
Input Voltage Waveform	Sinusoidal (utility or generator)
Nominal Input Voltage	230Vac
Low Loss Voltage	170Vac±3V (UPS) 110Vac±3V (Appliances)
Low Loss Return Voltage	180Vac±3V (UPS); 120Vac±3V (Appliances)
High Loss Voltage	280Vac±3V
High Loss Return Voltage	270Vac±3V
Max AC Input Voltage	280Vac
Nominal Input Frequency	50Hz / 60Hz (Adaptive)
Low Loss Frequency	40±1Hz
Low Loss Return Frequency	42±1Hz
High Loss Frequency	65±1Hz
High Loss Return Frequency	63±1Hz
Output Short Circuit Protection	Battery mode: Electronic Circuits
Efficiency (Line Mode)	>95% (Rated R load, battery full charged)
Transfer Time	10ms typical (UPS); 20ms typical (Appliances)
Output power derating: When AC input voltage drops to 110V or 170V depending on models, the output power will be derated.	 <p>Output Power ↑</p> <p>Rated Power</p> <p>50% Power</p> <p>110V 170V 280V Input Voltage →</p>

Table 2 Inverter Mode Specifications

INVERTER MODEL	6.2kW 48V
Rated Output Power	6200VA/6200W
Output Voltage Waveform	Pure Sine Wave
Output Voltage Regulation	230Vac \pm 5%
Output Frequency	50Hz / 60Hz (Adaptive)
Max. conversion efficiency	93%
Surge Capacity	2* rated power
Nominal DC Input Voltage	48Vdc
Cold Start Voltage	46.0Vdc
Low DC Warning Voltage @ load < 20% @ 20% \le load < 50% @ load \ge 50%	44.0Vdc 42.8Vdc 40.4Vdc
Low DC Warning Return Voltage @ load < 20% @ 20% \le load < 50% @ load \ge 50%	46.0Vdc 44.8Vdc 42.4Vdc
Low DC Cut-off Voltage @ load < 20% @ 20% \le load < 50% @ load \ge 50%	42.0Vdc 40.8Vdc 38.4Vdc

Table 3 General Specifications

INVERTER MODEL	6.2kW 48V
Safety Certification	CE
Operating Temperature Range	-10 $^{\circ}$ C ~ 50 $^{\circ}$ C
Storage temperature	-15 $^{\circ}$ C ~ 50 $^{\circ}$ C
Humidity	5% to 95% Relative Humidity (Non-condensing)

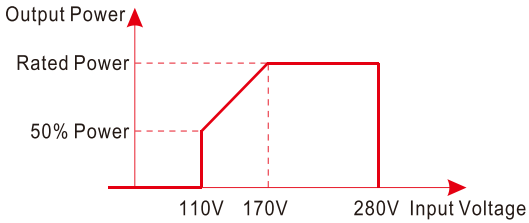
Table 4 Charge Mode Specifications

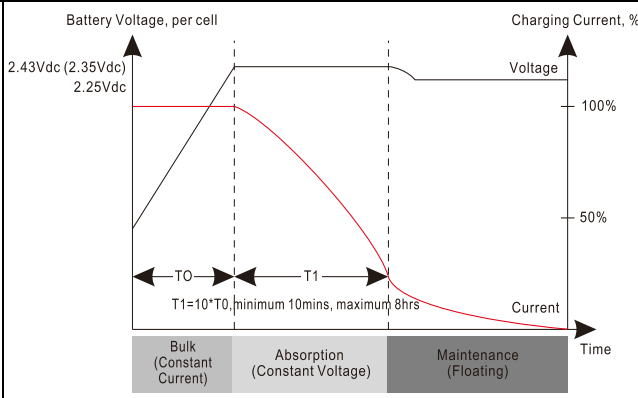
Utility Charging Mode		
INVERTER MODEL	6.2kW 48V	
Max Charging Current (PV+AC) (@ VI/P=230Vac)	120Amp	
Max Charging Current (AC) (@ VI/P=230Vac)	80Amp	
Bulk Charging Voltage	Lithium battery	58.4Vdc (16 strings)
	Flooded Battery	58.4Vdc
	AGM / Gel Battery	56.4Vdc
Floating Charging Voltage	54Vdc	
Overcharge Protection	63Vdc	
Charging Algorithm	3-Step	
Charging Curve	 <p>The graph illustrates the 3-step charging algorithm. The left y-axis represents Battery Voltage per cell (Vdc), with values 2.25Vdc and 2.43Vdc (2.35Vdc) marked. The right y-axis represents Charging Current (%), with 50% and 100% marked. The x-axis represents Time, divided into three stages: Bulk (Constant Current), Absorption (Constant Voltage), and Maintenance (Floating). The time intervals T0 and T1 are indicated, with the relationship $T1 = 10 * T0$ and a range of minimum 10mins to maximum 8hrs for T1.</p>	
Solar Input		
INVERTER MODEL	6.2kW 48V	
Rated Power	6500W	
Max. PV Array Open Circuit Voltage	500Vdc	
PV Array MPPT Voltage Range	60Vdc~450Vdc	
Max. Input Current	27A	

3.11 TROUBLE SHOOTING

Problem	LCD/LED/Buzzer	Explanation / Possible cause	What to do
Unit shuts down automatically during startup process.	LCD/LEDs and buzzer will be active for 3 seconds and then complete off.	The battery voltage is too low	Re-charge battery. Replace battery.
No response after power on.	No indication.	The battery voltage is far too low. Battery polarity is connected reversed.	Check if batteries and the wiring are connected well. Re-charge battery. Replace battery.
Mains exist but the unit works in battery mode.	Input voltage is displayed as 0 on the LCD and green LED is flashing.	Input protector is tripped	Check if AC breaker is tripped and AC wiring is connected well.
	Green LED is flashing.	Insufficient quality of AC power. (Shore or Generator)	Check if AC wires are too thin and/or too long. Check if generator (if applied) is working well or if input voltage range setting is correct. (UPS Appliance)
	Green LED is flashing.	Set "Solar First" as the priority of output source.	Change output source priority to Utility first.
When the unit is turned on, internal relay is switched on and off repeatedly.	LCD display and LEDs are flashing	Battery is disconnected.	Check if battery wires are connected well.
Buzzer beeps continuously and red LED is on.	Fault code 07	Overload error. The inverter is overload 110% and time is up.	Reduce the connected load by switching off some equipment.
	Fault code 05	Output short circuited.	Check if wiring is connected well and remove abnormal load.
	Fault code 02	Internal temperature of inverter component is over 100°C.	Check whether the air flow of the unit is blocked or whether the ambient temperature is too high.
	Fault code 03	Battery is over-charged.	Return to repair center.
		The battery voltage is too high.	Check if spec and quantity of batteries are meet requirements.
	Fault code 06/22	Output abnormal (Inverter voltage below than 190Vac or is higher than 260Vac)	Reduce the connected load. Return to repair center
	Fault code 08/09/15	Internal components failed.	Return to repair center.
Fault code 13	Over current or surge.	Restart the unit, if the error	

Problem	LCD/LED/Buzzer	Explanation / Possible cause	What to do
	Fault code 14	Bus voltage is too low.	happens again, please return to repair center.
	Another fault code	-	If the wires is connected well, please return to repair center.

Chapter 4 Storage Battery Introduction

4.1 Appearance is introduced

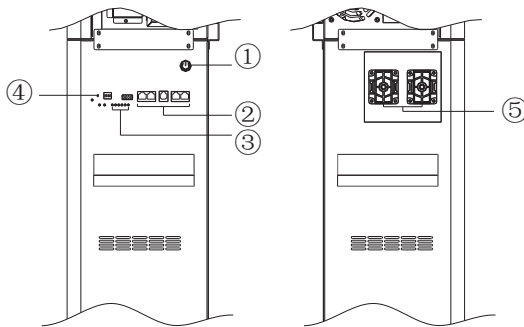

- 1 .Switch button
- 2 .Communication Interface
- 3 .Indicator Light
- 4 .Reset Switch
- 5 .Battery interface

4.2 Technical Specifications

Cell type	Square lithium iron battery
Rated capacity	15360Wh (Single Pack)
Nominal voltage	51.2V
Discharge voltage range	43.2-57.6V
Standard charging current	0.5C@25°C
Max.charging current	200A@25°C
Max.discharge current	200A @25°C
Depth of discharge DOD	0.9
Cycles	6000 cycles 80%DOD.@25°C
Working Temp.Range	Charge: 0°C~55°C Discharge: -20°C~55°C
Storage temperature(°C)	-15°C~50°C

Recommendation: Charge and discharge the battery every 3 months.

4.3 Comparison table of DIP switch settings

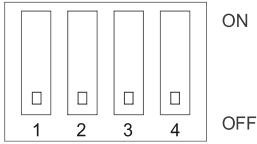

ADS	DIP Switch			
	#1	#2	#3	#4
0	OFF	OFF	OFF	OFF
1	ON	OFF	OFF	OFF
2	OFF	ON	OFF	OFF
3	ON	ON	OFF	OFF
4	OFF	OFF	ON	OFF
5	ON	OFF	ON	OFF
6	OFF	ON	ON	OFF
7	ON	ON	ON	OFF
8	OFF	OFF	OFF	ON
9	ON	OFF	OFF	ON
10	OFF	ON	OFF	ON
11	ON	ON	OFF	ON
12	OFF	OFF	ON	ON
13	ON	OFF	ON	ON
14	OFF	ON	ON	ON
15	ON	ON	ON	ON

(1) Single battery set using dial code:

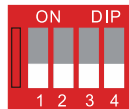

Single battery

(2) Multiple sets of batteries in parallel use the DIP settings:

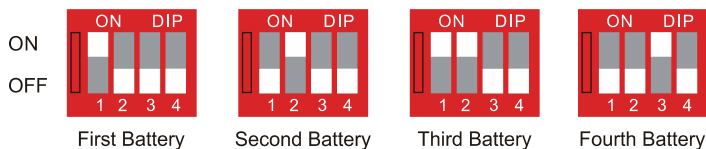

4.4 LED indicator description

Table 1 LED operating status indication

Status	Normal/Alarm/Protection	ON/OFF	RUN	ALM	Power indicator LED						Description	
		●	●	●	●	●	●	●	●	●		
Turn off	Dormancy	extinguish	extinguish	extinguish	extinguish	extinguish	extinguish	extinguish	extinguish	extinguish	extinguish	Total extinction
Stand-by	Normal	extinguish	Flash 1	extinguish	Based on power indicator						Standby status	
	Alerts	extinguish	Flash 1	Flash 3							Modular low voltage	
Charge	Normal	extinguish	Ever bright	extinguish	Maximum battery LED flashes (flashing 2), ALM does not flash on overcharge alarm						Maximum battery LED flashes (flashing 2), ALM does not flash on overcharge alarm	
	Alerts	extinguish	Ever bright	Flash 3								
	Overfill protection	Ever bright	Ever bright	extinguish	Ever bright	Ever bright	Ever bright	Ever bright	Ever bright	Ever bright	Ever bright	If there is no mains power, the indicator turns to standby
	Temperature, overcurrent, fail-safe	Ever bright	extinguish	Ever bright	extinguish	extinguish	extinguish	extinguish	extinguish	extinguish	extinguish	Stop charging
Discharge	Normal	extinguish	Flash 3	extinguish	Based on power indicator							
	Alerts	extinguish	Flash 3	Flash 3								
	Under-voltage protection	Ever bright	extinguish	extinguish	extinguish	extinguish	extinguish	extinguish	extinguish	extinguish	extinguish	Stop discharge
	Temperature, overcurrent, short circuit, reverse connection, failure protection	Ever bright	extinguish	Ever bright	extinguish	extinguish	extinguish	extinguish	extinguish	extinguish	extinguish	Stop discharge
Failure		extinguish	extinguish	Ever bright	extinguish	extinguish	extinguish	extinguish	extinguish	extinguish	extinguish	Stop charging and discharging

Table 2 Description of capacity indication

Status	Capacity indicator	Amount of electricity						Running light
		0 ~16.6%	16.6 ~33.2%	33.2 ~49.8%	49.8 ~66.4%	66.4 ~83.0%	83.0 ~100%	
Charging	L6	extinguish	extinguish	extinguish	extinguish	extinguish	Flash 2	Ever bright
	L5	extinguish	extinguish	extinguish	extinguish	Flash 2	Ever bright	
	L4	extinguish	extinguish	extinguish	Flash 2	Ever bright	Ever bright	
	L3	extinguish	extinguish	Flash 2	Ever bright	Ever bright	Ever bright	
	L2	extinguish	Flash 2	Ever bright	Ever bright	Ever bright	Ever bright	
	L1	Flash 2	Ever bright	Ever bright	Ever bright	Ever bright	Ever bright	
Discharge	L6	extinguish	extinguish	extinguish	extinguish	extinguish	Ever bright	Flash 3
	L5	extinguish	extinguish	extinguish	extinguish	Ever bright	Ever bright	
	L4	extinguish	extinguish	extinguish	Ever bright	Ever bright	Ever bright	
	L3	extinguish	extinguish	Ever bright	Ever bright	Ever bright	Ever bright	
	L2	extinguish	Ever bright	Ever bright	Ever bright	Ever bright	Ever bright	
	L1	Ever bright	Ever bright	Ever bright	Ever bright	Ever bright	Ever bright	

☒ Battery BMS RS485 interface definition

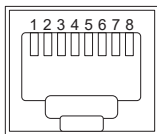

Pin number	RS485 Port
1、8	RS485-B
2、7	RS485-A
3、6	GND
4、5	NC

☒ Battery BMS CAN interface definition

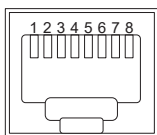

Pin number	CAN Port
9、10、11、14、16	NC
12	CANL
13	CANH
15	GND

4.5 Safety and precautions

1. The battery module must be used in conjunction with BMS, and the mixed use of batteries from different manufacturers is strictly prohibited.
2. Check the battery module voltage for damage; if there is any abnormality, please stop using it.
3. It is strictly forbidden to stack the whole trailer battery with fork plate during transportation and storage, and it is forbidden to stack battery modules when installing and transporting batteries. There are positive and negative lead terminals or sampling line lead ends, and it is strictly forbidden to squeeze, stack and place them down.
4. Parallel matching requirements for battery modules: (Notes before picking and installation)
 - (1) Two identical models and same capacity, The battery modules of the same voltage are connected in parallel to 51.2V.
 - (2) Serial use is strictly prohibited.
5. Parallel wires are included in the battery module packing box, and the parallel wires correspond to the battery modules. Mixed insertion is strictly prohibited.
6. It is forbidden to use or leave the battery module near high temperature and high heat sources, away from fire and water sources.
7. It is forbidden to disassemble the battery module, knock, throw or step on the battery module, and dismantle the BMS and dismantle the yellow tamper-evident sticker without authorization.
8. Before installing the battery module, check whether the open circuit voltage of the battery is within the normal range. The "positive" and "negative" signs are printed on the module, and the electrical properties should be correctly determined. It is strictly forbidden to reverse or short-circuit the battery.
9. Insulation tools and gloves should be used during installation and transportation, and metal-containing conductors such as watches, bracelets (bracelets) and rings should be removed from the wrist to prevent electric shock and short-circuit the positive and negative electrodes. During installation, the battery module poles need to be insulated and protected. If the poles are close to the battery rack and other conductors, the battery poles or battery racks need to be insulated and protected.
10. The recommended transportation method is for two people to carry it at the same time. The transportation tool is a safety rope or a load-bearing net bag. The battery box must be carried to the site. Violent construction is strictly prohibited to damage the product.
11. Please read this installation manual carefully before installation. If you have any questions, please contact your supplier.



www.sailsolarpv.com



www.sailsolaress.com

ADD: Building 7, Cross Border E-Commerce Supervision Zone Hefei, China